

SPST, SPDT, and DPDT Switches Demystified

I assure you that 99.99% of all toggle switches work as I explain below. The mechanical parts inside are designed to connect the terminals just as I explain here. Perhaps there are some Rube Goldberg switches out there that work opposite of this but they are few and far between and I assure you that the normal switches you buy will work as described below. One exception worth mentioning is that if a double throw switch is specified as ON-OFF-ON is means that there is a special middle position in which the center pole(s) does not touch either of the other poles. This is known as a "center off" switch. The normal double throw switches are specified as ON-NONE-ON which means they have no "center" position and are always in contact with one of the other pole(s).

SPST

A Single Pole Single Throw toggle switch connects or disconnects one terminal either to or from another. It is the simplest switch.

Bat UP = ON (terminals connected)
 Bat DOWN = OFF (terminals disconnected)

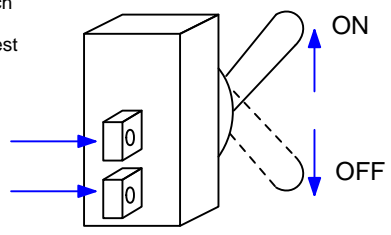

SPST Schematic Symbol



SPDT

A Single Pole Double Throw toggle switch connects a common terminal to one or the other of two terminals. It is always connected to one or the other. The two outside terminals are never connected by the switch.

To use a SPDT switch as a SPST switch just use the common terminal and either of the other terminals. So... you could use C and A or you could use C and B.

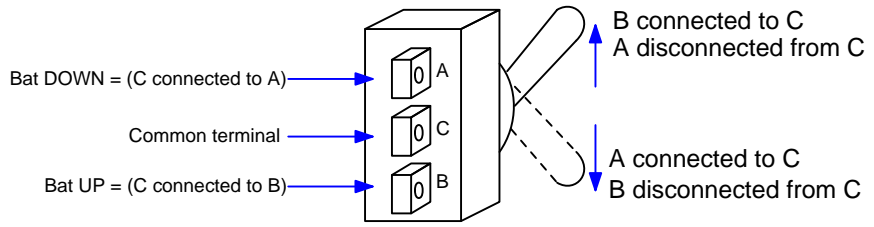

SPDT Schematic Symbol

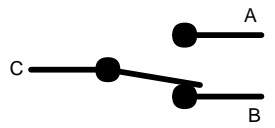

DPDT

A Double Pole Double Throw toggle switch acts exactly like two separate SPDT switches connected to the same switch bat. It has two separate common terminals and each of those is connected to one or the other of the other two terminals on the same side of the switch. The dotted line in the picture is to illustrate that the switch is actually two SPDT switches in one package with one switch bat.

A DPDT switch works just like two separate SPDT switches attached to the same switch bat.

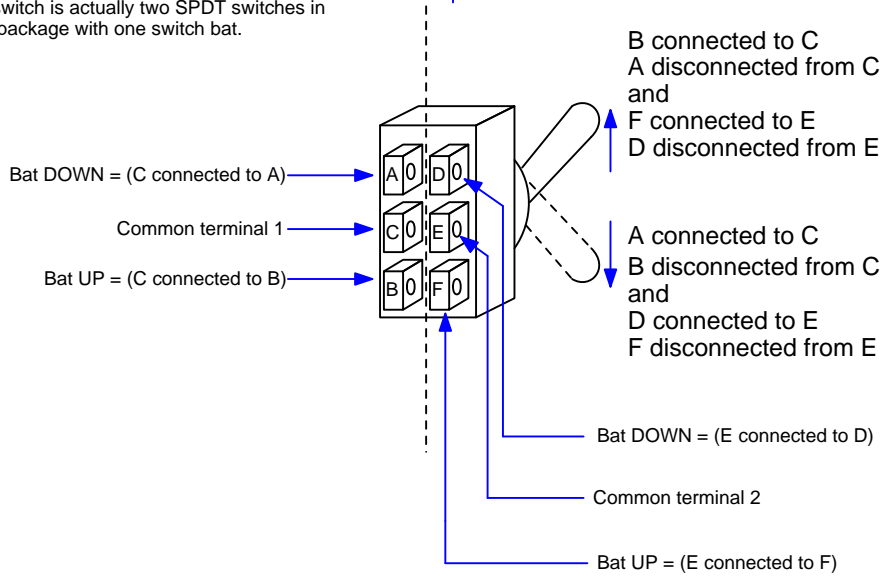

DPDT Schematic Symbol

